



PRODUCTOS DE PROTECCIÓN Y DESINFECCIÓN CONTRA COVID-19

Globalia Proteccion
www.globaliaproteccion.com
Distribuido por Garclos Inversiones SL





"Dragón"

Referencia DR1L: 901001



Características:

Compacto y económico dispensador infantil

Dimensiones: altura 1386 mm.

Estructura metálica.

Dispensador accionado mediante pedal.

Capacidad dispensador: 1000 ml.

Peso: 12 kilos

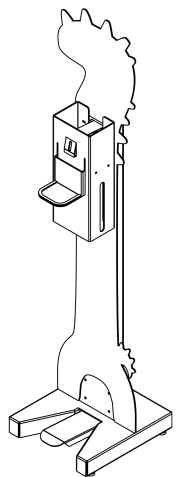
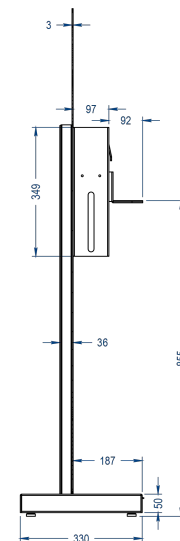
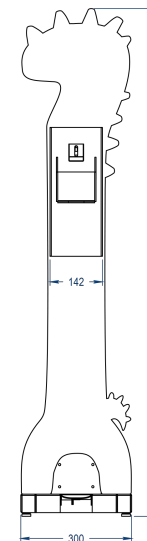



"Jirafa"

Referencia JR1L: 901002



Características:

Compacto y económico dispensador infantil

Dimensiones: altura 1386 mm.

Estructura metálica.

Dispensador accionado mediante pedal.

Capacidad dispensador: 1000 ml.

Peso: 12 kilos

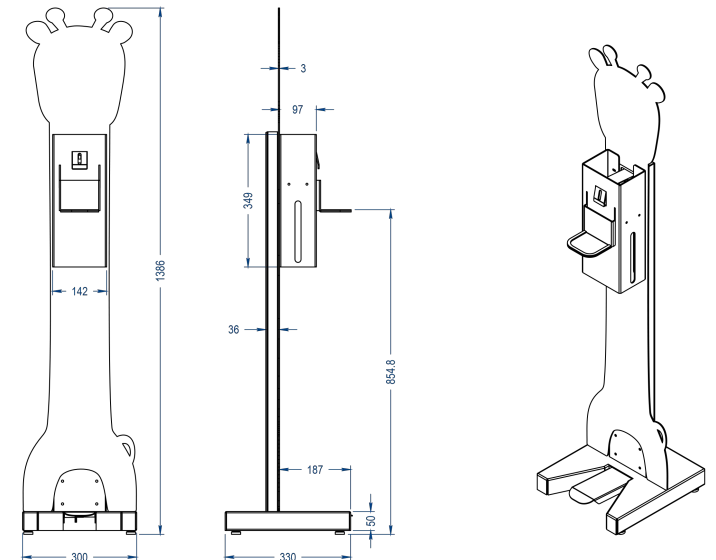



CONTACTO:

Garclos Inversiones SL.

Barcelona

www.globaliaproteccion.com

globalia@globaliaproteccion.com

garclos@movistar.es

tel. 00-34-659444713

